

Regarding
Leksell GammaPlan®

Document
CONFSTAT

Date
2025-09-16

Edition
04

Page
1 (65)



DICOM Conformance Statement

Leksell GammaPlan®

11.5

Contents

1	Introduction	6
1.1	Scope and field of application	6
1.2	Reference documents.....	6
1.3	Terminology.....	7
1.4	Important notes.....	7
	Scope.....	7
	Validation.....	8
	New versions of the DICOM Standard.....	8
2	Implementation Model.....	9
2.1	Applications data flow diagrams	9
	Verification SCU	9
	Verification SCP.....	9
	Storage SCP.....	10
	Storage SCU	10
	Query/Retrieve SCP	11
	File Set Reader	11
	File Set Writer	12
2.2	Functional definitions of Application Entity	12
	Elekta Storage Server.....	12
	Leksell GammaPlan®.....	12
2.3	Sequencing of Real World Activities.....	13
3	AE specifications.....	14
3.1	Elekta Storage Server AE Specification - Storage	14
	Association Establishment Policies.....	14
	Association Initiation by Real World Activity	15
	Association Acceptance Policy.....	15
3.2	Elekta Storage Server AE Specification - Verification	16
	Association Initiation by Real World Activity	17
	Association Acceptance Policy.....	17
3.3	Leksell GammaPlan® AE - Storage	18
	Association Establishment Policies.....	18
	Association Initiation by Real World Activity	19
	Association Initiation Policy.....	19
	Association Acceptance Policy.....	19
3.4	Leksell GammaPlan® AE – Verification	20
	Association Establishment Policies.....	20
	Association Initiation by Real World Activity	20
	Association Initiation Policy.....	21
	Association Acceptance Policy.....	21
3.5	Leksell GammaPlan® AE Specification – Query/Retrieve	21
	Association Establishment Policies.....	22
	Association Initiation by Real World Activity	22

Document CONFSTAT	Edition 04	Page 3 (65)
----------------------	---------------	----------------

Association Initiation Policy 22

4 Communication profiles 26

4.1 Supported Communication Stacks 26

4.2 TCP/IP Stack 26

4.3 OSI Stack 26

4.4 Physical Media Support 26

 Reading DICOM Object stored on CD-ROM or USB flash drive 26

 Writing DICOM Object to USB flash drives 28

5 Configuration 29

5.1 Elekta Storage Server 29

5.2 Leksell GammaPlan® 29

6 Support of Character Sets 30

7 Appendix A: Processing of DICOM Images 31

8 Appendix B: Import Processing of DICOM RT Structure Sets 35

9 Appendix C: Import Processing of DICOM RT Dose 38

10 Appendix D: Export of DICOM RT objects 43

11 Appendix E: Processing of CBCT images generated by Leksell Gamma Knife® 55

12 Appendix F: Anonymization of DICOM Attributes 58

13 Appendix G: Standard Extended/ Specialized / Private SOP Classes 63

13.1 Private Data Elements 63

13.2 Diagnosis Code Values 64

List of tables

Table 1: SOP Classes for storage supported by the Elekta Storage Server.	14
Table 2: Presentation context table: C-STORE service	16
Table 3: SOP Classes for verification supported by the Elekta Storage Server.	16
Table 4: Presentation context table: C-ECHO service.....	17
Table 5: SOP Classes for storage supported by Leksell GammaPlan®	18
Table 6: Presentation context table: C-STORE service for Leksell GammaPlan®	20
Table 7: SOP Classes for verification supported by Leksell GammaPlan®	20
Table 8: Presentation context table: C-ECHO service.....	21
Table 9: SOP Classes for Query/Retrieve supported by Leksell GammaPlan®	22
Table 10: Presentation context table: C-FIND service for Leksell GammaPlan®	24
Table 11: Presentation context table: C-GET and C-MOVE service for Leksell GammaPlan®	25
Table 12: Media Storage: Objects and Transfer	28
Table 13: Media Storage: Objects and Transfer supported by Leksell GammaPlan®	28
Table 14: Supported Composite Image SOP Classes	31
Table 15: Significant Attributes for Processing of DICOM Images.	34
Table 17: Significant Attributes for Import Processing of DICOM RT Structure Sets	37
Table 17: Significant Attributes for Import Processing of DICOM RT Dose	42
Table 18: DICOM RT Attributes exported by Leksell GammaPlan®	54
Table 19: DICOM attributes set in CBCT images generated by Leksell Gamma Knife®.	57
Table 20: Significant Elements when Anonymizing DICOM Objects	62
Table 21: Private Data Elements included in the RT Plan exported by Leksell GammaPlan®	64
Table 22: Possible values for Code Meaning attribute (0008,0104) and Code Value attribute (0008,0100) when exported by Leksell GammaPlan®	65

Document CONFSTAT	Edition 04	Page 5 (65)
----------------------	---------------	----------------

List of Figures

Figure 1 Application Data Flow Diagram - Verification SCU.....	9
Figure 2 Application Data Flow Diagram - Verification SCP.	9
Figure 3 Application Data Flow Diagram - Storage SCP.....	10
Figure 4 Application Data Flow Diagram - Storage SCU.	10
Figure 5 Application Data Flow Diagram – Query/Retrieve SCP.	11
Figure 6 Application Data Flow Diagram – File Set Reader from DICOM CD-R.....	11
Figure 7 Application Data Flow Diagram – File Set Writer to USB medium.....	12

Document CONFSTAT	Edition 04	Page 6 (65)
----------------------	---------------	----------------

1 Introduction

1.1 Scope and field of application

The scope of this DICOM conformance statement is to facilitate data exchange with Leksell GammaPlan®. This document specifies the conformance to the DICOM standard (formally called NEMA PS3/ISO 12052). It contains a short description of the applications involved and provides technical information about the data exchange capabilities of the equipment. The main elements describing these capabilities are the supported DICOM service object pairs (SOP) classes, Roles and Transfer Syntaxes.

1.2 Reference documents

NEMA PS3 / ISO 12052, *Digital Imaging and Communications in Medicine (DICOM) Standard*, National Electrical Manufacturer's Association, Rosslyn, VA, United States of America (available free at <http://medical.nema.org>).

1.3 Terminology

Term	Explanation
AE	Application Entity
AET	Application Entity Title
AP	Application Profile
FSR	File Set Reader
FSC	File Set Creator
PDU	Protocol data unit
SCP	Service Class Provider
SCU	Service Class User
SOP	Service Object Pair
UID	Unique Identifier

1.4 Important notes

This Conformance Statement by itself does not guarantee successful interoperability of Elekta equipment with non-Elekta equipment. The user (or user's agent) should be aware of the following issues:

Scope

The goal of DICOM is to facilitate inter-connectivity rather than interoperability. Interoperability refers to the ability of application functions, distributed over two or more systems, to work successfully together. The integration of medical devices into a networked environment may require application functions that are not specified within the scope of DICOM. Consequently, using only the information provided by this Conformance Statement does not guarantee interoperability of Elekta equipment with non-Elekta equipment. It is the user's responsibility to analyze thoroughly the application requirements and to specify a solution that integrates Elekta equipment with non-Elekta equipment.

Document CONFSTAT	Edition 04	Page 8 (65)
----------------------	---------------	----------------

Validation

Elekta equipment has been carefully tested to assure that the actual implementation of the DICOM interface corresponds with this Conformance Statement. Where Elekta equipment is linked to non-Elekta equipment, the first step is to compare the relevant Conformance Statements. If the Conformance Statements indicate that successful information exchange should be possible, additional validation tests will be necessary to ensure the functionality, performance, accuracy and stability of image and image related data. It is the responsibility of the user (or user's agent) to specify the appropriate test suite and to carry out the additional validation tests.

New versions of the DICOM Standard

The DICOM standard will evolve in future to meet the user's growing requirements and to incorporate new features and technologies. Elekta plans to adapt its equipment to future versions of the DICOM standard. In order to do so, Elekta reserves the right to make changes to its products or to discontinue its delivery. The user should ensure that any non-Elekta provider linking to Elekta equipment also adapts to future versions of the DICOM Standard. If not, the incorporation of DICOM enhancements into Elekta equipment may lead to loss of connectivity (in case of networking) and incompatibility (in case of media).

2 Implementation Model

The Elekta Neuro Treatment Planning system consist of one Elekta Storage Server Application Entity connected to one or more Leksell GammaPlan® Treatment Planning Workstations.

2.1 Applications data flow diagrams

The application data flows for the different services supported by the Elekta Storage Server and Leksell GammaPlan® are described below.

Verification SCU

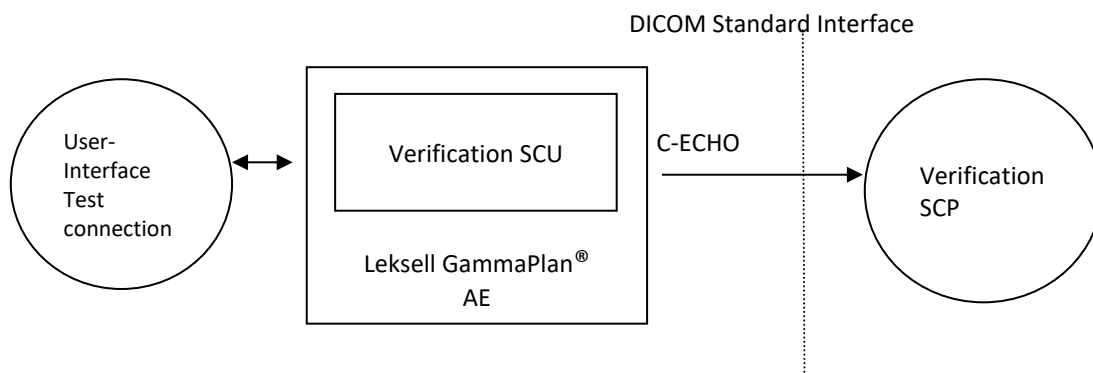

Figure 1 Application Data Flow Diagram - Verification SCU.

Verification SCP

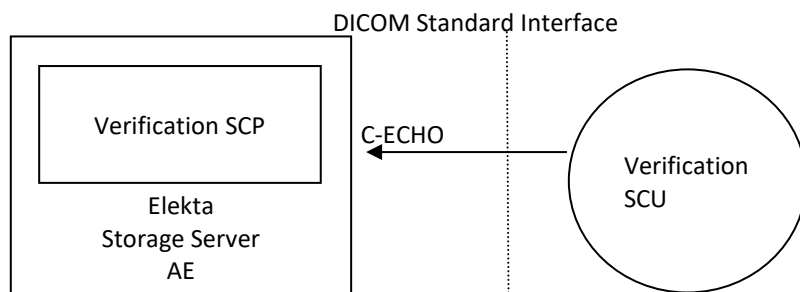

Figure 2 Application Data Flow Diagram - Verification SCP.

Storage SCP

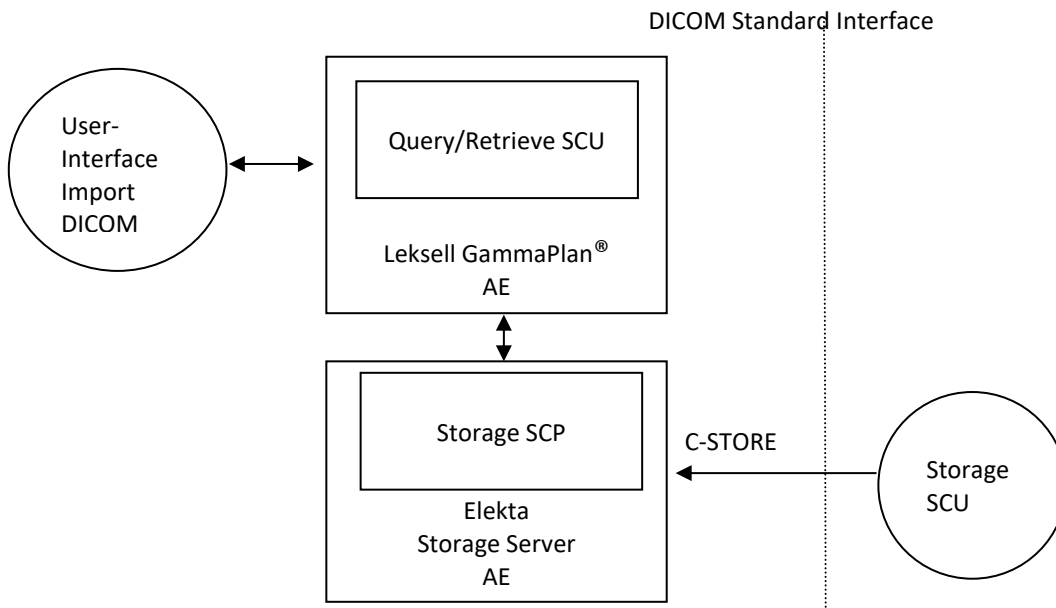

Figure 3 Application Data Flow Diagram - Storage SCP.

Storage SCU

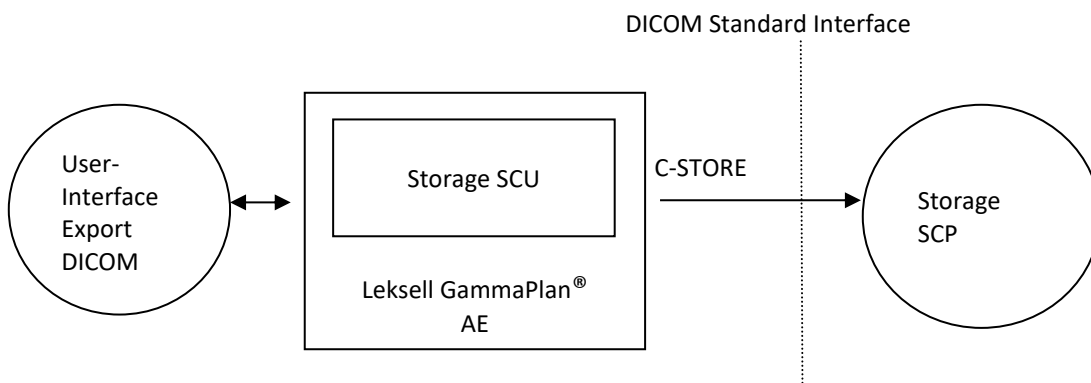

Figure 4 Application Data Flow Diagram - Storage SCU.

Query/Retrieve SCP

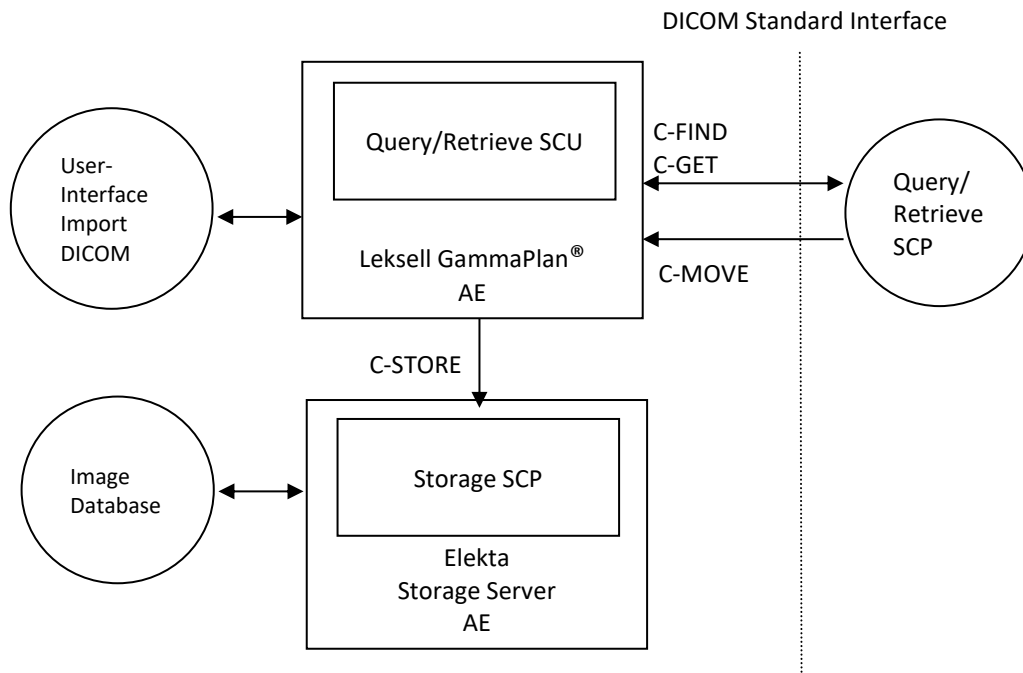

Figure 5 Application Data Flow Diagram – Query/Retrieve SCP.

File Set Reader

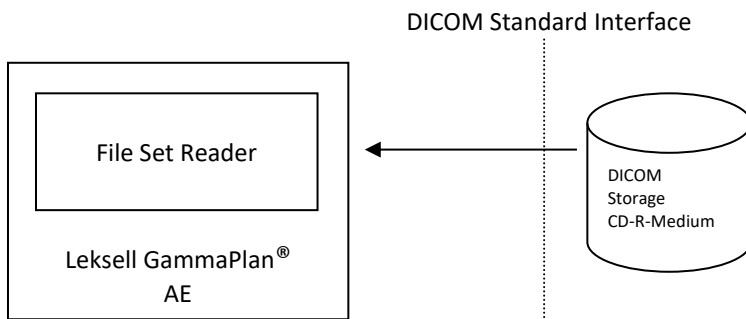

Figure 6 Application Data Flow Diagram – File Set Reader from DICOM CD-R.

Note: This is a partially conformant File Set Reader as it is able to perform M-READ but not MINQUIRE FILE Media Storage Operation.

File Set Writer

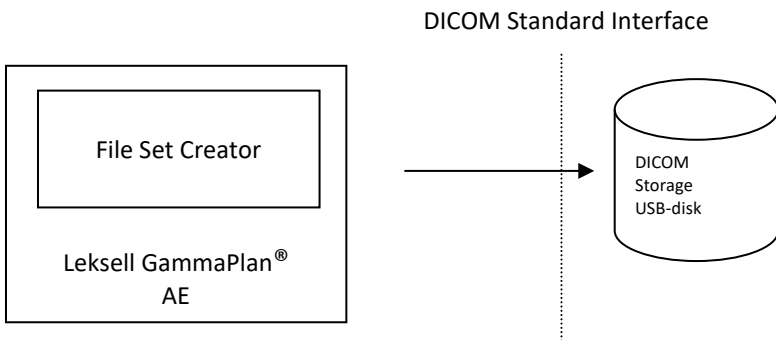

Figure 7 Application Data Flow Diagram – File Set Writer to USB medium.

Note: This is a partially conformant File Set Creator as it is able to perform M-WRITE but not M-INQUIRE FILE or MINQUIRE FILESET Media Storage Operation.

2.2 Functional definitions of Application Entity

Elekta Storage Server

The Elekta Storage Server waits for another application to connect at the TCP/IP port number 104. When another application makes a DICOM association request, the Storage Server acts as a SCP for the storage service class: It stores the DICOM objects in the inbox of the Leksell GammaPlan® Treatment Planning Workstation. The Storage Server also acts as a SCP for the verification service class: It responds to C-ECHO requests from other applications.

Leksell GammaPlan®

Leksell GammaPlan® is a DICOM Client (SCU) for the purpose of

- Importing DICOM Images, DICOM RT Dose and DICOM RT Structure Sets, drawn in the image planes of an already imported image series.
- Requesting a remote query/retrieve SCP to perform a search and match to the keys specified in the request in order to display the results in the Leksell GammaPlan® user interface. Depending on user action (Import) Leksell GammaPlan® sends a C-GET or a C-MOVE request to initiate a C-STORE operation on the SCP to start an image transfer from the remote query/retrieve SCP to Leksell GammaPlan®. A C-MOVE request is only sent if the query/retrieve SCP does not support the C-GET service.
- Exporting DICOM Images and DICOM Structure sets object to a remote Service Class Provider (DICOM Server). Leksell GammaPlan® also exports DICOM RT Dose and DICOM RT Plan objects. The RT objects can be exported together with an image series. Only 3D volumes can be exported. The DICOM RT Dose object contains the global dose distribution within the skull for the currently active treatment plan. A DICOM RT Plan object is created and used to connect the dose object with the structure sets and images. The DICOM RT Object can be exported together with CT, MR and PET images.
- Displaying the available DICOM attributes of a DICOM object during import or on request for DICOM images or DICOM RT objects. All available DICOM attributes are parsed and

displayed (besides the exceptions described below) but not specifically used for any other processing in Leksell GammaPlan®. Not displayed are value representations OB and OW, sequences that have no value field and elements with an irrelevant retired group length. Furthermore, the number of displayed elements per column is limited to maintain readability and a clear indication that the maximum displayable number of elements is exceeded is displayed.

- Writing DICOM Images and DICOM Structure sets objects to a USB flash drive. Leksell GammaPlan® also writes DICOM RT Dose and DICOM RT Plan objects. This is a partially conformant File Set Creator (FSC) as it is able to perform M-WRITE but not M-INQUIRE FILE SET or M-INQUIRE FILE Media Storage Operation.
- Reading DICOM object stored on a CD-ROM. This is a partially conformant File Set Reader (FSR) as it is able to perform M-READ but not M-INQUIRE FILE Media Storage Operation.
- Echo Utility for test and validation purposes. It sends a verify request to a specified DICOM node. It acts as a SCU for the verification service class.

2.3 Sequencing of Real World Activities

The user “verification” of a remote application can be made during a configuration session of the remote applications. Retrieve of images is only possible if results from a previous “Search...” operation exists and those entities can be selected for “Import”.

3 AE specifications

3.1 Elekta Storage Server AE Specification - Storage

The Elekta Storage Server Application Entity provides Standard Conformance to the following DICOM V3.0 SOP classes for storage as a SCP:

SOP Class Name	UID
CT Image Storage	1.2.840.10008.5.1.4.1.1.2
MR Image Storage	1.2.840.10008.5.1.4.1.1.4
XA Image Storage	1.2.840.10008.5.1.4.1.1.12.1
PET Image Storage	1.2.840.10008.5.1.4.1.1.128
RT Structure Set Storage	1.2.840.10008.5.1.4.1.1.481.3
SC Image Storage	1.2.840.10008.5.1.4.1.1.7
RT Dose Storage	1.2.840.10008.5.1.4.1.1.481.2

Table 1: SOP Classes for storage supported by the Elekta Storage Server.

Association Establishment Policies

General

The Elekta Storage Server accepts association in response to C-STORE requests from other Applications Entities. It will accept C-STORE requests for CT, MR, XA, PET, RT Structure Set, SC SOP classes, and RT Dose and in this case will act as storage service class provider. The Storage Server is a LINUX daemon, waits for C-STORE requests, and performs the necessary operations upon it receiving such requests.

Number of Associations

The number of simultaneous associations that will be accepted by the Elekta Storage Server is limited to 5.

Asynchronous Nature

The Elekta Storage Server does not perform asynchronous operations window negotiation.

Implementation Identifying Information

The Elekta Storage Server does not export any DICOM object. The only occasion where an Implementation Identifier may be used is during the establishment of the association with a DICOM peer. For this reason the implementation identifying information of the OFFIS DCMTK DICOM toolkit has been kept unchanged:

IMPLEMENTATION_CLASS_UID = 1.2.276.0.7230010.3.0.3.6.9

IMPLEMENTATION_VERSION = OFFIS_DCMTK_369

Association Initiation by Real World Activity

The Elekta Storage Server never initiates an association.

Association Acceptance Policy

Remote System Requests Image Storage on the Elekta Storage Server

Associated Real World Activity – Storage Provider

A DICOM AE sends a storage request to the Elekta Storage Server. If the request is accepted the images and objects are stored on the Elekta Storage Server.

Presentation context table - storage

Presentation Context Table					
Abstract Syntax		Transfer Syntax List		Role	Extended Negotiation
Name	UID	Name	UID		
CT Image Storage	1.2.840.10008.5.1.4.1.1.2	Implicit VR Little Endian	1.2.840.10008.1.2	SCP	None
		Explicit VR Little Endian	1.2.840.10008.1.2.1		
		Explicit VR Big Endian	1.2.840.10008.1.2.2		
MR Image Storage	1.2.840.10008.5.1.4.1.1.4	Implicit VR Little Endian	1.2.840.10008.1.2	SCP	None
		Explicit VR Little Endian	1.2.840.10008.1.2.1		
		Explicit VR Big Endian	1.2.840.10008.1.2.2		
X-Ray Angiographic Image Storage	1.2.840.10008.5.1.4.1.1.12.1	Implicit VR Little Endian	1.2.840.10008.1.2	SCP	None
		Explicit VR Little Endian	1.2.840.10008.1.2.1		
		Explicit VR Big Endian	1.2.840.10008.1.2.2		
PET Image Storage	1.2.840.10008.5.1.4.1.1.12.8	Implicit VR Little Endian	1.2.840.10008.1.2	SCP	None
		Explicit VR Little Endian	1.2.840.10008.1.2.1		
		Explicit VR Big Endian	1.2.840.10008.1.2.2		
RT Structure Set Storage	1.2.840.10008.5.1.4.1.1.48.1.3	Implicit VR Little Endian	1.2.840.10008.1.2	SCP	None

		Explicit VR Little Endian	1.2.840.10008.1.2.1		
		Explicit VR Big Endian	1.2.840.10008.1.2.2		
Secondary Capture	1.2.840.10008.5.1.4.1.1.7	Implicit VR Little Endian	1.2.840.10008.1.2	SCP	None
Image Storage		Explicit VR Little Endian	1.2.840.10008.1.2.1		
		Explicit VR Big Endian	1.2.840.10008.1.2.2		
RT Dose Storage	1.2.840.10008.5.1.4.1.1.48 1.2	Implicit VR Little Endian	1.2.840.10008.1.2	SCP	None
		Explicit VR Little Endian	1.2.840.10008.1.2.1		
		Explicit VR Big Endian	1.2.840.10008.1.2.2		

Table 2: Presentation context table: C-STORE service

C-STORE SCP conformance

The Elekta Storage Server is Conformance Level 0 Storage SCP. The stored attributes may be accessed only through Leksell GammaPlan® and only for display. The duration of storage of these attributes is at the user discretion.

Presentation context acceptance criterion

The Elekta Storage Server will accept any context listed in Table 2. There is no check for duplicate contexts.

Transfer syntax selection policies

The preference in acceptance of Transfer Syntaxes is:

Implicit Little Endian above Explicit Little Endian above Explicit Big Endian

3.2 Elekta Storage Server AE Specification - Verification

The Elekta Storage Server Application Entity provides Standard Conformance to the Verification DICOM V3.0 SOP class as a SCP:

SOP Class Name	UID
Verification	1.2.840.10008.1.1

Table 3: SOP Classes for verification supported by the Elekta Storage Server.

General

The Elekta Storage Server accepts association in response to C-ECHO requests and act as verification service class provider. The Storage Server is a LINUX daemon, waits for C-ECHO requests, and performs the necessary operations upon it receiving such requests.

Number of Associations

The number of simultaneous associations that will be accepted by the Elekta Storage Server is limited to 5.

Asynchronous Nature

The Elekta Storage Server does not perform asynchronous operations window negotiation.

Implementation Identifying Information

The Elekta Storage Server does not export any DICOM object. The only occasion where an Implementation Identifier may be used is during the establishment of the association with a DICOM peer. For this reason the implementation identifying information of the OFFIS DCMTK DICOM toolkit has been kept unchanged:

IMPLEMENTATION_CLASS_UID = 1.2.276.0.7230010.3.0.3.6.9

IMPLEMENTATION_VERSION = OFFIS_DCMTK_369

Association Initiation by Real World Activity

The Elekta Storage Server never initiates an association.

Association Acceptance Policy

Remote system requests verification

Associated real world activity – Verification Provider

A remote DICOM AE wish to verify the application level communication using the C-ECHO command.

Presentation context table - verification

Presentation Context Table					
Abstract Syntax		Transfer Syntax List		Role	Extended Negotiation
Name	UID	Name	UID		
Verification	1.2.840.10008.1.1	Implicit VR Little Endian	1.2.840.10008.1.2	SCP	None
		Explicit VR Little Endian	1.2.840.10008.1.2.1	SCP	None
		Explicit VR Big Endian	1.2.840.10008.1.2.2	SCP	None

Table 4: Presentation context table: C-ECHO service

C-ECHO SCP conformance

The Elekta Storage Server provides standard conformance to the C-ECHO service as a Service Class Provider.

Presentation context acceptance criterion

The only accepted presentation context is defined in Table 4.

Transfer syntax selection policies

The preference in acceptance of Transfer Syntaxes is:

Implicit Little Endian above Explicit Little Endian above Explicit Big Endian

3.3 Leksell GammaPlan® AE - Storage

Leksell GammaPlan® Application Entity provides Standard Conformance the following DICOM V3.0 SOP classes for storage as a SCU:

SOP Class Name	UID
CT Image Storage	1.2.840.10008.5.1.4.1.1.2
MR Image Storage	1.2.840.10008.5.1.4.1.1.4
PET Image Storage	1.2.840.10008.5.1.4.1.1.128
¹ SC Image Storage	1.2.840.10008.5.1.4.1.1.7
RT Dose Storage	1.2.840.10008.5.1.4.1.1.481.2
RT Structure Set Storage	1.2.840.10008.5.1.4.1.1.481.3
RT Plan Storage	1.2.840.10008.5.1.4.1.1.481.5

Table 5: SOP Classes for storage supported by Leksell GammaPlan®.

Association Establishment Policies

General

The maximum PDU size for Leksell GammaPlan® can be configurable from a minimum of 4 Kbytes. The upper limit is 128Kbytes. The default value is 64 Kbytes.

Number of Associations

Leksell GammaPlan® supports one active association at a time as a Service Class User.

Asynchronous Nature

Leksell GammaPlan® does not support asynchronous operations and will not perform asynchronous window negotiation.

¹ Only Secondary Capture of tomographic images can be sent to a remote Application Entity.

Implementation Identifying Information

IMPLEMENTATION_CLASS_UID = 1.2.276.0.7230010.3.0.3.6.9

IMPLEMENTATION_VERSION = OFFIS_DCMTK_369

Association Initiation by Real World Activity

Leksell GammaPlan® sends a C-STORE request to a remote Applications Entities.

Association Initiation Policy

Leksell GammaPlan® initiates associations for the purpose of

- Export DICOM objects to PACS, Linac or other similar systems

Association Acceptance Policy

Leksell GammaPlan® does not accept associations.

Requests for DICOM Object Storage on Remote Systems

Associated Real World Activity – Storage User

Leksell GammaPlan® requests associations with remote systems that it wishes to send DICOM objects to.

Presentation context table - storage

Presentation Context Table					
Abstract Syntax		Transfer Syntax List		Role	Extended Negotiation
Name	UID	Name	UID		
CT Image Storage	1.2.840.10008.5.1.4.1.1.2	Implicit VR Little Endian	1.2.840.10008.1.2	BOTH	None
MR Image Storage	1.2.840.10008.5.1.4.1.1.4	Implicit VR Little Endian	1.2.840.10008.1.2	BOTH	None
PET Image Storage	1.2.840.10008.5.1.4.1.1.128	Implicit VR Little Endian	1.2.840.10008.1.2	BOTH	None
RT Dose Storage	1.2.840.10008.5.1.4.1.1.481.2	Implicit VR Little Endian	1.2.840.10008.1.2	BOTH	None
RT Structure Set Storage	1.2.840.10008.5.1.4.1.1.481.3	Implicit VR Little Endian	1.2.840.10008.1.2	BOTH	None
RT Plan Storage	1.2.840.10008.5.1.4.1.1.481.5	Implicit VR Little Endian	1.2.840.10008.1.2	BOTH	None
Secondary Capture Storage	1.2.840.10008.5.1.4.1.1.7	Implicit VR Little Endian	1.2.840.10008.1.2	BOTH	None

Table 6: Presentation context table: C-STORE service for Leksell GammaPlan®.

C-STORE SCU conformance

Leksell GammaPlan® provides standard conformance for Storage as a SCU. The systems performs a Conformance Level 0 for Storage, i.e., not all DICOM Type 1 and 2 attributes received earlier by another module may have been stored for re-export.

Presentation context acceptance criterion

Not applicable.

Transfer syntax selection policies

Not applicable.

3.4 Leksell GammaPlan® AE – Verification

Leksell GammaPlan® Application Entity provides Standard Conformance the following DICOM V3.0 SOP classes for verification as a SCU for :

SOP Class Name	UID
Verification	1.2.840.10008.1.1

Table 7: SOP Classes for verification supported by Leksell GammaPlan®.

Association Establishment Policies

General

The maximum PDU size for Leksell GammaPlan® can be configurable from a minimum of 4 Kbytes. The upper limit is 128Kbytes. The default value is 64 Kbytes.

Number of Associations

Leksell GammaPlan® supports one active association at a time as a Service Class User.

Asynchronous Nature

Leksell GammaPlan® does not support asynchronous operations and will not perform asynchronous window negotiation.

Implementation Identifying Information

IMPLEMENTATION_CLASS_UID = 1.2.276.0.7230010.3.0.3.6.9

IMPLEMENTATION_VERSION = OFFIS_DCMTK_369

Association Initiation by Real World Activity

Leksell GammaPlan® sends a C-ECHO request to a remote Applications Entities.

Association Initiation Policy

Leksell GammaPlan® initiates associations for the purpose of

- Verify the application level communication to another system

Association Acceptance Policy

Leksell GammaPlan® does not accept associations.

Remote system requests verification

Associated real world activity – Verification User

Leksell GammaPlan® requests associations from remote systems to verify the application level communication using the C-ECHO command.

Presentation context table - Verification

Presentation Context Table					
Abstract Syntax		Transfer Syntax List		Role	Extended
Name	UID	Name	UID		Negotiation
Verification	1.2.840.10008.1.1	Implicit VR Little Endian	1.2.840.10008.1.2	SCU	None

Table 8: Presentation context table: C-ECHO service

C-ECHO SCU conformance

Leksell GammaPlan® provides standard conformance for Verification as SCU.

Presentation context acceptance criterion

Not applicable.

Transfer syntax selection policies

Not applicable.

3.5 Leksell GammaPlan® AE Specification – Query/Retrieve

Leksell GammaPlan® Application Entity provides Standard Conformance the following DICOM V3.0 SOP classes for Query/Retrieve as a SCU²:

SOP Class Name	UID
Patient Root Query/Retrieve Information Model - FIND	1.2.840.10008.5.1.4.1.2.1.1

² A license is required for the Query/Retrieve functionality.

Study Root Query/Retrieve Information Model - FIND	1.2.840.10008.5.1.4.1.2.2.1
Patient Root Query/Retrieve Information Model - GET	1.2.840.10008.5.1.4.1.2.1.3
Patient Root Query/Retrieve Information Model - MOVE	1.2.840.10008.5.1.4.1.2.1.2

Table 9: SOP Classes for Query/Retrieve supported by Leksell GammaPlan®.

Association Establishment Policies

General

The maximum PDU size for Leksell GammaPlan® can be configurable from a minimum of 4 Kbytes. The upper limit is 128Kbytes. The default value is 64 Kbytes.

Number of Associations

Leksell GammaPlan® supports one active association at a time as a Service Class User.

Asynchronous Nature

Leksell GammaPlan® does not support asynchronous operations and will not perform asynchronous window negotiation.

Implementation Identifying Information

IMPLEMENTATION_CLASS_UID = 1.2.276.0.7230010.3.0.3.6.9

IMPLEMENTATION_VERSION = OFFIS_DCMTK_369

Association Initiation by Real World Activity

Leksell GammaPlan® sends a C-FIND request to a remote Applications Entity followed by a C-GET request if the Entity supports C-GET. A C-MOVE request is sent otherwise.

Association Initiation Policy

Leksell GammaPlan® initiates associations for the purpose of

- Finding DICOM objects on remote Application Entities
- Retrieve DICOM objects from remote Application Entities

Requests for finding DICOM Object on Remote Systems

Associated Real World Activity - Find

Leksell GammaPlan® sends a C-FIND request when the user queries a remote Query/Retrieve SCP for patients, studies, series or objects. The search on the STUDY level is performed using the Study Root Query Retrieve Information Model with the following tags:

Description	Tag	Value
-------------	-----	-------

Patient Name	(0010,0010)	The value is entered in the GUI. Non ascii letters included in the entered value will be replaced by a question mark (?).
Patient ID	(0010,0020)	The value is entered in the GUI
Study Date	(0008,0020)	A date range is entered in the GUI.
Query/Retrieve level	(0008,0052)	STUDY
Study Time	(0008,0030)	Empty
Study ID	(0020,0010)	Empty
Study Instance UID	(0020,000d)	Empty

The search on the SERIES level is performed using the Patient Root Query Retrieve Information Model with the following tags:

Description	Tag	Value
Patient ID	(0010,0020)	From the STUDY level query.
Study Instance UID	(0020,000d)	From the STUDY level query
Query/Retrieve level	(0008,0052)	SERIES
Modality	(0008,0060)	Empty
Series Instance UID	(0020,000e)	Empty
Series Number	(0020,0011)	Empty

The search on the IMAGE level is performed using the Patient Root Query Retrieve Information Model with the following tags:

Description	Tag	Value
Patient ID	(0010,0020)	From the STUDY level query.
Study Instance UID	(0020,000d)	From the STUDY level query
Series Instance UID	(0020,000e)	From the SERIES level query
Query/Retrieve level	(0008,0052)	IMAGE
SOP Instance UID	(0008,0018)	Empty
Instance Number	(0020,0013)	Empty

The attributes with empty values or with wild cards "*" or "?" above are retrieved from the Query/Retrieve SCP. Leksell GammaPlan® does not support code extension techniques multiple

values of Specific Character Sets are not supported.

Presentation context table - Find

Presentation Context Table					
Abstract Syntax		Transfer Syntax List		Role	Extended Negotiation
Name	UID	Name	UID		
Patient Root Query/Retrieve Information Model – FIND	1.2.840.10008.5.1.4.1.2.1.1	Implicit VR Little Endian	1.2.840.10008.1.2	BOTH	None
Study Root Query/Retrieve Information Model – FIND	1.2.840.10008.5.1.4.1.2.2.1	Implicit VR Little Endian	1.2.840.10008.1.2	BOTH	None

Table 10: Presentation context table: C-FIND service for Leksell GammaPlan®.

C-FIND SCU conformance

Leksell GammaPlan® provides standard conformance for the C-FIND service as SCU.

Presentation context acceptance criterion

Not applicable.

Transfer syntax selection policies

Not applicable.

Requests for retrieving DICOM Object on Remote Systems

Associated Real World Activity – Move/Get

Leksell GammaPlan® requests associations for retrieving DICOM objects on remote DICOM AE. On user selection of a specific DICOM series or a DICOM object, a C-GET request is sent to systems supporting the C-GET service. If C-GET service is not supported a C_MOVE request is sent. When retrieving a selected DICOM series a C-FIND request on the IMAGE level is sent before the C-GET/C-MOVE request. The C-GET/C-MOVE request will include the following tags:

Description	Tag	Value
Patient ID	0010,0020	From the previous C-FIND query
Study Instance UID	0020,000d	From the previous C-FIND query
Series Instance UID	0020,000e	From the previous C-FIND query
SOP Instance UID	0008,0018	A vector of values from the preceding C-FIND query when retrieving

		DICOM series. One value when retrieving a DICOM object.
--	--	--

Presentation context table – Move/Get

Presentation Context Table					
Abstract Syntax		Transfer Syntax List		Role	Extended Negotiation
Name	UID	Name	UID		
Patient Root Query/Retrieve Information Model - GET	1.2.840.10008.5.1.4.1.2.1.3	Implicit VR Little Endian	1.2.840.10008.1.2	BOTH	None
Patient Root Query/Retrieve Information Model - MOVE	1.2.840.10008.5.1.4.1.2.1.2	Implicit VR Little Endian	1.2.840.10008.1.2	BOTH	None

Table 11: Presentation context table: C-GET and C-MOVE service for Leksell GammaPlan®.

C-GET conformance

Leksell GammaPlan® provides standard conformance for the C-GET service as SCU.

C-MOVE SCU conformance

Leksell GammaPlan® provides standard conformance for the C-MOVE service as SCU.

4 Communication profiles

4.1 Supported Communication Stacks

The Elekta Storage Server and Leksell GammaPlan® provides DICOM V3.0 TCP/IP Network Communication Support as defined in part 8 of the DICOM standard.

4.2 TCP/IP Stack

Elekta Storage Server inherits the TCP/IP stack from the LINUX operating system upon which they execute.

4.3 OSI Stack

Not supported.

4.4 Physical Media Support

Reading DICOM Object stored on CD-ROM or USB flash drive

Specification

Leksell GammaPlan® can read DICOM part 10 formatted Objects stored on CD-R or USB flash drive with the ISO/IEC 9660 Media Format. All DICOM objects on the CD-R or USB flash drive will be sent to the Elekta Storage Server. I.e. the DICOM Directory File (DICOMDIR) is not used and it is not possible to select separate files to be stored. The Leksell GammaPlan® is then not conformant to any application profiles defined in the DICOM standard. DICOM objects without Meta information will also be sent to the Elekta Storage Server.

Leksell GammaPlan® is partially conformant as FSR because it supports the M-READ service but does not the M-INQUIRE FILE service. The following table defines which objects are read by the application and which transfer syntaxes are supported:

Information Object Definition	Service Object Pair Class UID	Transfer Syntax	UID
CT Image	1.2.840.10008.5.1.4.1.1.2	Implicit VR Little Endian	1.2.840.10008.1.2
		Explicit VR Little Endian	1.2.840.10008.1.2.1
		Explicit VR Big Endian	1.2.840.10008.1.2.2
		JPEG Lossless, Non-Hierarchical, First-Order Prediction (Process 14 [Selection Value 1])	1.2.840.10008.1.2.4.70
		JPEG Lossless, Non-Hierarchical (Process 14)	1.2.840.10008.1.2.4.57
MR Image	1.2.840.10008.5.1.4.1.1.4	Implicit VR Little Endian	1.2.840.10008.1.2

		Explicit VR Little Endian	1.2.840.10008.1.2.1
		Explicit VR Big Endian	1.2.840.10008.1.2.2
		JPEG Lossless, Non-Hierarchical, First-Order Prediction (Process 14 [Selection Value 1])	1.2.840.10008.1.2.4.70
		JPEG Lossless, Non-Hierarchical (Process 14)	1.2.840.10008.1.2.4.57
X-Ray Angiographic Image	1.2.840.10008.5.1.4.1.1.12.1	Implicit VR Little Endian	1.2.840.10008.1.2
		Explicit VR Little Endian	1.2.840.10008.1.2.1
		Explicit VR Big Endian	1.2.840.10008.1.2.2
		JPEG Lossless, Non-Hierarchical, First-Order Prediction (Process 14 [Selection Value 1])	1.2.840.10008.1.2.4.70
		JPEG Lossless, Non-Hierarchical (Process 14)	1.2.840.10008.1.2.4.57
PET Image	1.2.840.10008.5.1.4.1.1.128	Implicit VR Little Endian	1.2.840.10008.1.2
		Explicit VR Little Endian	1.2.840.10008.1.2.1
		Explicit VR Big Endian	1.2.840.10008.1.2.2
		JPEG Lossless, Non-Hierarchical, First-Order Prediction (Process 14 [Selection Value 1])	1.2.840.10008.1.2.4.70
		JPEG Lossless, Non-Hierarchical (Process 14)	1.2.840.10008.1.2.4.57
Secondary Capture Image	1.2.840.10008.5.1.4.1.1.7	Implicit VR Little Endian	1.2.840.10008.1.2
		Explicit VR Little Endian	1.2.840.10008.1.2.1
		Explicit VR Big Endian	1.2.840.10008.1.2.2
		JPEG Lossless, Non-Hierarchical, First-Order Prediction (Process 14 [Selection Value 1])	1.2.840.10008.1.2.4.70
		JPEG Lossless, Non-Hierarchical (Process 14)	1.2.840.10008.1.2.4.57
RT Structure	1.2.840.10008.5.1.4.1.1.481.3	Implicit VR Little Endian	1.2.840.10008.1.2

Set Storage		Explicit VR Little Endian	1.2.840.10008.1.2.1
		Explicit VR Big Endian	1.2.840.10008.1.2.2
RT Dose Storage	1.2.840.10008.5.1.4.1.1.481.2	Implicit VR Little Endian	1.2.840.10008.1.2
		Explicit VR Little Endian	1.2.840.10008.1.2.1
		Explicit VR Big Endian	1.2.840.10008.1.2.2

Table 12: Media Storage: Objects and Transfer

Writing DICOM Object to USB flash drives

Specification

Leksell GammaPlan® can write DICOM part 10 formatted objects to USB flash drives. It is partially conformant as FSC as it is able to perform M-WRITE but not M-INQUIRE FILE SET or M-INQUIRE FILE Media Storage Operation. It is not conformant to any application profiles defined in the DICOM standard. The following table defines which objects are written by the applications and which transfer syntaxes are supported:

Information Object Definition	Service Object Pair Class UID	Transfer Syntax	UID
CT Image	1.2.840.10008.5.1.4.1.1.2	Implicit VR Little Endian	1.2.840.10008.1.2
MR Image	1.2.840.10008.5.1.4.1.1.4	Implicit VR Little Endian	1.2.840.10008.1.2
X-Ray Angiographic Image	1.2.840.10008.5.1.4.1.1.12.1	Implicit VR Little Endian	1.2.840.10008.1.2
PET Image	1.2.840.10008.5.1.4.1.1.128	Implicit VR Little Endian	1.2.840.10008.1.2
Secondary Capture Image	1.2.840.10008.5.1.4.1.1.7	Implicit VR Little Endian	1.2.840.10008.1.2
RT Dose Storage	1.2.840.10008.5.1.4.1.1.481.2	Implicit VR Little Endian	1.2.840.10008.1.2
RT Structure Set Storage	1.2.840.10008.5.1.4.1.1.481.3	Implicit VR Little Endian	1.2.840.10008.1.2
RT Plan Storage	1.2.840.10008.5.1.4.1.1.481.5	Implicit VR Little Endian	1.2.840.10008.1.2

Table 13: Media Storage: Objects and Transfer supported by Leksell GammaPlan®

5 Configuration

5.1 Elekta Storage Server

The Application Entity Title for the Storage Server and the port is defined in a configuration file. The default AET (as generated when the application is installed) is ELEKTA_STORAGE and the port is 104. This configuration is intended to be performed by Elekta service engineers only.

The maximum PDU size for the Storage Server is configurable from a minimum of 4 Kbytes. The upper limit is 128Kbytes. The default value is 16 Kbytes.

5.2 Leksell GammaPlan®

The AET of Leksell GammaPlan® can be configured in the user interface. Leksell GammaPlan® listens to port 50 001. The IP-address is configured when installing the Leksell GammaPlan® workstation. The AET, IP-address and port of the remote Storage and Query/Retrieve SCP can be configured in the user interface. The maximum PDU size for Leksell GammaPlan® is configurable from a minimum of 4 Kbytes. The upper limit is 128Kbytes. The default value is 64 Kbytes.

Some timeout values can be configured by an Elekta service engineer if the system does not behave as expected.

Connection timeout in seconds when connecting to SCPs. Default value 60s.

DIMSE timeout in seconds for receiving data. Default value 60s.

ACSE timeout in seconds used by timer for message timeouts during association negotiation. Default value 60s.

6 Support of Character Sets

Leksell GammaPlan® supports the following character sets in addition to the default when handling DICOM objects:

- ISO_IR 100
- ISO_IR 101
- ISO_IR 109
- ISO_IR 110
- ISO_IR 144
- ISO_IR 127
- ISO_IR 126
- ISO_IR 138
- ISO_IR 148
- ISO_IR 192

Code extension techniques are currently not supported.

7 Appendix A: Processing of DICOM Images

The following Elements of Composite SOP Instances are processed by Leksell GammaPlan® when importing or processing DICOM image objects.

SOP Instances conforming to the following Composite Image SOP Classes are fully supported for Leksell GammaPlan®.

CT Image
MR Image
X-Ray Angiographic Image
PET Image
Secondary Capture Image

Table 14: Supported Composite Image SOP Classes

Since Leksell GammaPlan® has no use for unlisted elements, they are not read.

PATIENT MODULE ATTRIBUTES (Table C.7-1 in DICOM standard)		
Attribute Name	Tag	Significance
Patient's Name	(0010,0010)	Identification
Patient ID	(0010,0020)	Identification

GENERAL STUDY MODULE ATTRIBUTES (Table C.7-3 in DICOM standard)		
Attribute Name	Tag	Significance
Study Date	(0008,0020)	Identification
Study Time	(0008,0030)	Identification
Study Instance UID	(0020,000D)	Separation of a stack in several series

GENERAL IMAGE MODULE ATTRIBUTES (Table C.7-9 in DICOM standard)		
Attribute Name	Tag	Significance
Instance Number	(0020,0013)	User information
Patient Orientation	(0020,0020)	3D reconstruction

GENERAL SERIES MODULE ATTRIBUTES (Table C.7-5a in DICOM standard)		
---	--	--

Attribute Name	Tag	Significance
Modality	(0008,0060)	Identification/Validation. The accepted values are CT, MR, XA, PT, OT and DS. Note DS is a retired enumerated value for modality since the introduction of XA, but it can still be found in some image headers.
Series Number	(0020,0011)	Separation of a stack in several series
Series Instance UID	(0020,000E)	Separation of a stack in several series

IMAGE PLANE MODULE ATTRIBUTES (Table C.7-10 in DICOM standard)		
Attribute Name	Tag	Significance
Image Orientation (Patient)	(0020,0037)	3D reconstruction
Pixel spacing	(0028,0030)	3D reconstruction. Only square pixels are supported for tomographic or angiographic images. For tomographic images, a small ratio deviation (below 1 %) of row and column spacing is allowed.
Slice Location	(0020,1041)	Separation of a stack in several series
Image Position (Patient)	(0020,0032)	3D reconstruction
Slice Thickness	(0018,0050)	3D reconstruction/validation. For a valid 3D reconstruction, it is required that "slice thickness" and "spacing between slices" do not differ more than an application-configured tolerance.

IMAGE PIXEL MODULE ATTRIBUTES (Table C.7-11a in DICOM standard)		
Attribute Name	Tag	Value
Pixel Data	(7FE0,0010)	Pixel data interpretation and display
Include 'Image Pixel Description Macro Attributes' Table C.7-11c		See IMAGE PIXEL MACRO ATTRIBUTES

IMAGE PIXEL DESCRIPTION MACRO ATTRIBUTES (Table C.7-11c in DICOM standard)		
Attribute Name	Tag	Significance
Samples per pixel	(0028,0002)	Pixel data interpretation and display. Only 1 sample per pixel is supported.
Photometric Interpretation	(0028,0004)	Pixel data interpretation. Only MONOCHROME1 and MONOCHROME2 are supported.
Bits Allocated	(0028,0100)	Pixel data interpretation and display. Only 8 and 16 bit are supported.

Bits stored	(0028,0101)	Pixel data interpretation and display
High Bit	(0028,0102)	Pixel data interpretation and display
Pixel Representation	(0028,0103)	Pixel data interpretation and display
Columns	(0028,0011)	Pixel data interpretation and display
Rows	(0028,0010)	Pixel data interpretation and display
Pixel Aspect Ratio	(0028,0034)	Pixel data interpretation and display

CT IMAGE ATTRIBUTES (Table C.8-3 in DICOM standard)

Attribute Name	Tag	Significance
Rescale slope	(0028,1053)	Pixel data interpretation and display
Rescale intercept	(0028,1052)	Pixel data interpretation and display
KVP	(0020,0012)	Used during electron density calculations.

GENERAL EQUIPMENT ATTRIBUTES (Table C.7-8 in DICOM standard)

Attribute Name	Tag	Significance
Pixel Padding Value	(0028,0120)	Pixel data interpretation and display
Manufacturer	(0008,0070)	Used during electron density calculations.
Manufacturer's Model Name	(0008,1090)	Used during electron density calculations.
Station Name	(0008,1010)	Used during electron density calculations.

FRAME OF REFERENCE MODULE ATTRIBUTES (Table C.7-6 in DICOM standard)

Attribute Name	Tag	Significance
Frame of Reference UID	(0020,0052)	Reference to other DICOM objects

VOI LUT MODULE ATTRIBUTES (Table C.11.2-b in DICOM standard)

Attribute Name	Tag	Significance
Window Center	(0028,1050)	Pixel data interpretation and display
Window Width	(0028,1051)	Pixel data interpretation and display

SOP COMMON MODULE ATTRIBUTES (Table C.12-1 in DICOM standard)		
Attribute Name	Tag	Significance
SOP Instance UID	(0008,0018)	Identification
Specific Character Set	(0008,0005)	Used for decoding of other attributes of type SH, LO, ST, PN, LT, UC and UT
SOP Class UID	(0008,0016)	Validation

PET SERIES MODULE ATTRIBUTES (Table C.8-60 in DICOM standard)		
Attribute Name	Tag	Significance
Series Type	(0054,1000)	Validation. For rejection of dynamic PET studies.

MULTI-FRAME MODULE ATTRIBUTES (Table C.7-14 in DICOM standard)		
Attribute Name	Tag	Significance
Number Of Frames	(0028,0008)	Validation. For rejection of multi frame Angio studies.

Table 15: Significant Attributes for Processing of DICOM Images.

8 Appendix B: Import Processing of DICOM RT Structure Sets

The following Elements of DICOM RT Structure Set Instances are processed by Leksell GammaPlan® when importing or processing DICOM RT Structure Sets.

Elements use by Leksell GammaPlan® are listed. Since Leksell GammaPlan® has no use for unlisted elements, they are not read.

PATIENT MODULE ATTRIBUTES (Table C.7-1 in DICOM standard)			
Attribute Name	Tag	Type	Significance
Patient ID	(0010,0020)	2	Identification User information

GENERAL STUDY MODULE ATTRIBUTES (Table C.7-3 in DICOM standard)			
Attribute Name	Tag	Type	Significance
Study Instance UID	(0020,000D)	1	Identification User information

RT SERIES MODULE ATTRIBUTES (Table C.8-37 in DICOM standard)			
Attribute Name	Tag	Type	Significance
Modality	(0008,0060)	1	User information The accepted value is RTSTRUCT.
Series Instance UID	(0020,000E)	1	Identification User information

FRAME OF REFERENCE MODULE ATTRIBUTES (Table C.7-6 in DICOM standard)			
Attribute Name	Tag	Type	Significance
Frame of Reference UID	(0020,0052)	1	User information Used as a fallback for determining the study that is associated with the RT Structure Set item if no match has been found using the Referenced SOP Instance UID (see table C.8-41). The first match which also matches the orientation will be associated with the RT Structure Set item. The RT Structure Set item will be rejected during import if no match is found.

STRUCTURE SET MODULE ATTRIBUTES (Table C.8-41 in DICOM standard)			
Attribute Name	Tag	Type	Significance
Structure Set Label	(3006,0002)	1	User information
Instance Number	(0020,0013)	3	Identification User information
Referenced Frame of Reference Sequence	(3006,0010)	3	
>Frame of Reference UID	(0020,0052)	1	See table C.7-6.
>RT Referenced Study Sequence	(3006,0012)	3	
>>RT Referenced Series Sequence	(3006,0014)	1	
>>>Contour Image Sequence	(3006,0016)	1	
>>>>Referenced SOP Instance UID	(0008,1155)	1	Used to determine which study the RT structure is associated with.
Structure Set ROI Sequence	(3006,0020)	1	One volume is created for each item in the sequence.
>ROI Number	(3006,0022)	1	Used to find the observation associated with the RT Structure Set ROI or information to the user if the import was unsuccessful.
>Referenced Frame of Reference UID	(3006,0024)	1	Used to find the ROI structure set item with the same Frame of Reference UID. The RT structure Set item will be rejected during import if no match is found.
>ROI Name	(3006,0026)	2	Used for setting the name of the imported ROI (may be unqualified if needed) or information to the user if the import was unsuccessful.

ROI CONTOUR MODULE ATTRIBUTES (Table C.8-42 in DICOM standard)			
Attribute Name	Tag	Type	Significance
ROI Contour Sequence	(3006,0039)	1	Used for obtaining contours for a structure set ROI item. ROI item will not be imported if this attribute is of size zero.
>Referenced ROI Number	(3006,0084)	1	Import will be rejected if no match is found in the Structure Set ROI Sequence (3006,0020).
>ROI Display Color	(3006,002A)	3	Used to set the color of the generated volume. The nearest supported color will be chosen.

>Contour Sequence	(3006,0040)	3	RT Structure Set item will not be imported if this is empty.
>>Contour Image Sequence	(3006,0016)	3	
>>>Referenced SOP Instance UID	(0008,1155)	1	Used to determine which study the RT structure is associated with.
>>Contour Geometric Type	(3006,0042)	1	Only CLOSED_PLANAR is supported, RT structures with other types will not be imported.
>>Contour Data	(3006,0050)	1	Used for generating volume contours.

RT ROI OBSERVATIONS MODULE ATTRIBUTES (Table C.8-44 in DICOM standard)			
Attribute Name	Tag	Type	Significance
RT ROI Observations Sequence	(3006,0080)	1	Observation items for the ROIs. A ROI without a matching RT ROI Observation item is imported as a volume of type Object.
>Referenced ROI Number	(3006,0084)	1	Used when looking up the observation for a specific RT Structure Set item.
>RT ROI Interpreted Type	(3006,00A4)	2	PTV: ROI is imported as a volume of type Target. AVOIDANCE: ROI is imported as a volume of type Risk. All other values or <null>: ROI is imported as a volume of type Object.

SOP COMMON MODULE ATTRIBUTES (Table C.12-1 in DICOM standard)			
Attribute Name	Tag	Type	Significance
SOP Instance UID	(0008,0018)	1	Identification
Specific Character Set	(0008,0005)	3	Identification User information Used for decoding of other attributes of type SH, LO, ST, PN, LT, UC and UT.

Table 16: Significant Attributes for Import Processing of DICOM RT Structure Sets

9 Appendix C: Import Processing of DICOM RT Dose

The following Elements of DICOM RT Dose Instances are processed by Leksell GammaPlan® when importing or processing DICOM RT Dose.

Elements use by Leksell GammaPlan® are listed. Since Leksell GammaPlan® has no use for unlisted elements, they are not read.

RT DOSE MODULE ATTRIBUTES (Table C.8-39 in DICOM standard)			
Attribute Name	Tag	Type	Significance
Instance Number	(0020,0013)	3	Identification User information
Dose Summation Type	(3004,000A)	1	Pixel data interpretation and display. Only Dose Summation Type PLAN is supported.
Dose Type	(3004,0004)	1	Pixel data interpretation and display. Only Dose Type PHYSICAL OR EFFECTIVE are supported.
Dose Units	(3004,0002)	1	Pixel data interpretation and display. Only Dose Unit GY is supported.
Dose Comment	(3004,0006)	3	User information
Grid Frame Offset Vector	(3004,000C)	1C	Used when creating dose images from RT Dose to determine equidistant slice spacing and gap and overlap for RT Dose. For a valid 3D reconstruction for DICOM RT Dose, it is required that "spacing between slices" is equidistant and overlap and slice gap do not differ more than an application-configured tolerance.
Tissue Heterogeneity Correction	(3004,0014)	3	User information
Dose Grid Scaling	(3004,000E)	1	Pixel data interpretation and display

OVERLAY PLANE MODULE ATTRIBUTES (Table C.9-2 in DICOM standard)			
Attribute Name	Tag	Type	Significance
Overlay Type	(6000,0040)	3	User information Not used, but user will be informed if it is present in imported RT Dose.

RT DVH MODULE ATTRIBUTES (Table C.8-40 in DICOM standard)

Attribute Name	Tag	Type	Significance
DVH Sequence	(3004,0050)	3	User information Not used, but user will be informed if it is present in imported RT Dose.

STRUCTURE SET MODULE ATTRIBUTES (Table C.8-41 in DICOM standard)			
Attribute Name	Tag	Type	Significance
Structure Set ROI Sequence	(3006,0020)	3	User information Not used, but user will be informed if it is present in imported RT Dose.

ROI CONTOUR MODULE ATTRIBUTES (Table C.8-42 in DICOM standard)			
Attribute Name	Tag	Type	Significance
ROI Contour Sequence	(3006,0039)	3	User information Not used, but user will be informed if it is present in imported RT Dose.

RT DOSE ROI MODULE ATTRIBUTES (Table C.8-43 in DICOM standard)			
Attribute Name	Tag	Type	Significance
RT Dose ROI Sequence	(3004,0010)	3	User information Not used, but user will be informed if it is present in imported RT Dose.

GENERAL EQUIPMENT MODULE ATTRIBUTES (Table C.7-8 in DICOM standard)			
Attribute Name	Tag	Type	Significance
Software Versions	(0018,1020)	3	User information
Manufacturer	(0008,0070)	2	User information
Manufacturer's Model Name	(0008,1090)	3	User information

MULTI-FRAME MODULE ATTRIBUTES (Table C.7-14 in DICOM standard)			
--	--	--	--

Attribute Name	Tag	Type	Significance
Number Of Frames	(0028,0008)	1	Interpretation of dose data. Rejection of RT Dose studies. Only dose with more than one frame is supported.

IMAGE PLANE MODULE ATTRIBUTES (Table C.7-10 in DICOM standard)			
Attribute Name	Tag	Type	Significance
Pixel spacing	(0028,0030)	2	User information Interpretation of dose data
Image Orientation (Patient)	(0020,0037)	1	Interpretation of dose data
Image Position (Patient)	(0020,0032)	1	Interpretation of dose data

IMAGE PIXEL MODULE ATTRIBUTES (Table C.7-11a in DICOM standard)			
Attribute Name	Tag	Type	Significance
Pixel Data	(7FE0,0010)	1	Pixel data interpretation and display
Include 'Image Pixel Description Macro Attributes' Table C.7-11c		1	See IMAGE PIXEL MACRO ATTRIBUTES

IMAGE PIXEL DESCRIPTION MACRO ATTRIBUTES (Table C.7-11c in DICOM standard)			
Attribute Name	Tag	Type	Significance
Bits Allocated	(0028,0100)	1	Pixel data interpretation and display
Bits Stored	(0028,0101)	1	Pixel data interpretation and display
High Bit	(0028,0102)	1	Pixel data interpretation and display
Columns	(0028,0011)	1	Pixel data interpretation and display
Rows	(0028,0010)	1	Pixel data interpretation and display
Pixel Representation	(0028,0103)	1	Pixel data interpretation and display

FRAME OF REFERENCE MODULE ATTRIBUTES (Table C.7-6 in DICOM standard)			
---	--	--	--

Attribute Name	Tag	Type	Significance
Frame of Reference UID	(0020,0052)	1	User information Spatial relation reference.

SOP COMMON MODULE ATTRIBUTES (Table C.12-1 in DICOM standard)			
Attribute Name	Tag	Type	Significance
SOP Instance UID	(0008,0018)	1	Identification Only RT Dose with one object are supported. RT Dose cannot be imported twice to same examination.
Specific Character Set	(0008,0005)	3	Used for decoding of other attributes of type SH, LO, ST, PN, LT, UC and UT
Instance Creation Date	(0008,0012)	3	User information
Instance Creation Time	(0008,0013)	3	User information

RT SERIES MODULE ATTRIBUTES (Table C.8-37 in DICOM standard)			
Attribute Name	Tag	Type	Significance
Series Instance UID	(0020,000E)	1	Identification
Modality	(0008,0060)	1	Identification The accepted value is RTDOSE.
Series Description	(0008,103E)	3	Identification User information

GENERAL STUDY MODULE ATTRIBUTES (Table C.7-3 in DICOM standard)			
Attribute Name	Tag	Type	Significance
Study Date	(0008,0020)	2	Identification User information
Study Time	(0008,0030)	2	Identification User information
Study ID	(00020,0010)	2	User information
Study Instance UID	(0020,000D)	1	Identification

PATIENT MODULE ATTRIBUTES (Table C.7-1 in DICOM standard)			
--	--	--	--

Attribute Name	Tag	Type	Significance
Patient's Name	(0010,0010)	2	User information
Patient ID	(0010,0020)	2	Identification User information

Table 17: Significant Attributes for Import Processing of DICOM RT Dose

10 Appendix D: Export of DICOM RT objects

Leksell GammaPlan® can export RT Dose IOD (Table A.18.3-1 in DICOM standard PS3.3), RT Structure Set IOD (Table A.19.3-1 in DICOM standard PS3.3) and RT Plan IOD (PS3.3 Table A.20.3-1 in DICOM standard PS3.3) with the attributes described in this section.

GENERAL IMAGE MODULE ATTRIBUTES (Table C.7-9 in DICOM standard)			
Attribute Name	Tag	Type	Value
Instance Number	(0020,0013)	2	Empty
Image Type	(0008,0008)	3	DERIVED\SECONDARY\DOSE

IMAGE PLANE MODULE ATTRIBUTES (Table C.7-10 in DICOM standard)			
Attribute Name	Tag	Type	Value
Pixel Spacing	(0028,0030)	1	<value depending on data – grid size>
Image Orientation (Patient)	(0020,0037)	1	<value depending on data>
Image Position (Patient)	(0020,0032)	1	<value depending on data >
Slice Thickness	(0018,0050)	2	Empty

IMAGE PIXEL MODULE ATTRIBUTES (Table C.7-11a in DICOM standard)			
Attribute Name	Tag	Type	Value
Pixel Data	(7FE0,0010)	1C	<value depending on data – dose values>
Include 'Image Pixel Description Macro Attributes' Table C.7-11c			See IMAGE PIXEL MACRO ATTRIBUTES

IMAGE PIXEL DESCRIPTION MACRO ATTRIBUTES (Table C.7-11c in DICOM standard)			
Attribute Name	Tag	Type	Value
Samples per Pixel	(0028,0002)	1	1
Photometric Interpretation	(0028,0004)	1	MONOCHROME2
Rows	(0028,0010)	1	<value depending on data – pixels covering the selected object>
Columns	(0028,0011)	1	<value depending on data – pixels covering the selected

			object >
Bits Allocated	(0028,0100)	1	16
Bits Stored	(0028,0101)	1	16
High Bit	(0028,0102)	1	15
Pixel Representation	(0028,0103)	1	0

MULTI-FRAME MODULE ATTRIBUTES (Table C.7-14 in DICOM standard)			
Attribute Name	Tag	Type	Value
Number of Frames	(0028,0008)	1	<value depending on data – frames covering the selected object>
Frame Increment Pointer	(0028,0009)	1	(3004,000C)

RT DOSE MODULE ATTRIBUTES (Table C.8-39 in DICOM standard)			
Attribute Name	Tag	Type	Value
Samples per Pixel	(0028,0002)	1C	1
Photometric Interpretation	(0028,0004)	1C	MONOCHROME2
Bits Allocated	(0028,0100)	1C	16
Bits Stored	(0028,0101)	1C	16
High Bit	(0028,0102)	1C	15
Pixel Representation	(0028,0103)	1C	0
Dose Units	(3004,0002)	1	GY
Dose Type	(3004,0004)	1	PHYSICAL
Instance Number	(0020,0013)	3	Empty
Dose Comment	(3004,0006)	3	Dose algorithm: <alg> where <alg> is the dose algorithm used to compute the dose (TMR Classic, TMR 10, or Convolution).
Dose Summation Type	(3004,000A)	1	PLAN
Referenced RT Plan Sequence	(300C,0002)	1C	<One item>
>Include 'SOP Instance Reference			<Reference to RT Plan object>

Macro' Table 10-11			
Grid Frame Offset Vector	(3004,000C)	1C	<value depending on data>
Dose Grid Scaling	(3004,000E)	1C	<value depending on data>

STRUCTURE SET MODULE ATTRIBUTES (Table C.8-41 in DICOM standard)			
Attribute Name	Tag	Type	Value
Structure Set Label	(3006,0002)	1	ROIs from LGP
Structure Set Date	(3006,0008)	2	Empty
Structure Set Time	(3006,0009)	2	Empty
Referenced Frame of Reference Sequence	(3006,0010)	3	<one item>
>Frame of Reference UID	(0020,0052)	1	<frame of reference in image study>
>RT Referenced Study Sequence	(3006,0012)	3	<one item>
>>Include 'SOP Instance Reference Macro' Table 10-11			<reference to study containing the contour>
>>RT Referenced Series Sequence	(3006,0014)	1	<one item>
>>>Series Instance UID	(0020,000E)	1	<series instance UID of image study>
>>>Contour Image Sequence	(3006,0016)	1	<one item per image in the study >
>>>>Include 'Image SOP Instance Reference Macro' Table 10-3			<reference to image containing the contour>
Structure Set ROI Sequence	(3006,0020)	3	<one item per Volume>
>ROI Number	(3006,0022)	1	<sequence number starting at 1>
>Referenced Frame of Reference UID	(3006,0024)	1	<frame of reference UID>
>ROI Name	(3006,0026)	2	<User defined Volume name>
>ROI Generation Algorithm	(3006,0036)	2	MANUAL

ROI CONTOUR MODULE ATTRIBUTES (Table C.8-42 in DICOM standard)			
Attribute Name	Tag	Type	Value
ROI Contour Sequence	(3006,0039)	1	<one item per Volume>
>ROI Display Color	(3006,002A)	3	<user defined Volume color>
>Contour Sequence	(3006,0040)	3	<one item per Region in Volume>
>>Contour Image Sequence	(3006,0016)	3	<Optional: One item if a reference to an image exists>
>>>Include 'Image SOP Instance Reference Macro' Table 10-3			<reference to image containing the contour>
>>Contour Geometric Type	(3006,0042)	1	CLOSED_PLANAR
>>Number of Contour Points	(3006,0046)	1	<number of Vertices in Region>
>>Contour Data	(3006,0050)	1	<vertex coordinates in DICOM patient coordinates>
>Referenced ROI Number	(3006,0084)	1	<reference to ROI number>

RT ROI OBSERVATIONS MODULE ATTRIBUTES (Table C.8-44 in DICOM standard)			
Attribute Name	Tag	Type	Value
RT ROI Observations Sequence	(3006,0080)	1	<One item per Volume>
>Observation Number	(3006,0082)	1	<Index starting at 0>
>Referenced ROI Number	(3006,0084)	1	<Reference to ROI Item>
>ROI Observation Label	(3006,0085)	3	<User defined Volume name> Truncated to 16 chars
>RT ROI Interpreted Type	(3006,00A4)	2	If volume type target: PTV If volume type risk: AVOIDANCE If skull volume: EXTERNAL Otherwise: Empty

>ROI Interpreter	(3006,00A6)	2	Empty
------------------	-------------	---	-------

RT GENERAL PLAN MODULE ATTRIBUTES (Table C.8-45 in DICOM standard)			
Attribute Name	Tag	Type	Value
RT Plan Label	(300A,0002)	1	<User defined plan name> MOSAIQ gets the Course ID from the first two digits in this string.
RT Plan Name	(300A,0003)	3	<user defined plan name>
RT Plan Description	(300A,0004)	3	<user defined plan comment>
RT Plan Date	(300A,0006)	2	If plan approved in a version after LGP 11.1: <Date of approval> Otherwise:<empty>
RT Plan Time	(300A,0007)	2	If plan approved in a version after LGP 11.1 <Time of approval> Otherwise:<empty>
RT Plan Geometry	(300A,000C)	1	PATIENT
Referenced Structure Set Sequence	(300C,0060)	1C	<One Item>
>>Include 'SOP Instance Reference Macro' Table 10-11			SOP Class UID and SOP Instance UID of RT Structure Set on which the RT Plan is based.

RT PRESCRIPTION MODULE ATTRIBUTES (Table C.8-46 in DICOM standard)			
Attribute Name	Tag	Type	Value
Dose Reference Sequence	(300A,0010)	3	<One item per target>
>>Include 'Private Data Elements' Table 21: Private Data Elements included in the RT Plan exported by Leksell GammaPlan®.			See 13.1
>Dose Reference Number	(300A,0012)	1	<Unique number for each target>
>Dose Reference Structure Type	(300A,0014)	1	SITE
>Dose Reference	(300A,0016)	3	<User defined treatment prefix><User defined target

Description			name>
>Dose Reference Type	(300A,0020)	1	TARGET
>Target Prescription Dose	(300A,0026)	3	<Target prescription dose [Gy]>

RT PATIENT SETUP MODULE ATTRIBUTES (Table C.8-48 in DICOM standard)			
Attribute Name	Tag	Type	Value
Patient Setup Sequence	(300A,0180)	1	<One item per shot run>
>Patient Position	(0018,5100)	1C	HFS/HFP
>Patient Setup Number	(300A,0182)	1	<Sequence number starting at 1>
>Fixation Device Sequence	(300A,0190)	3	<Zero or one item>
>>Fixation Device Type	(300A,0192)	1	HEADFRAME/BITEBLOCK/MASK
>>Fixation Device Label	(300A,0194)	2	Empty
>>Fixation Device Pitch Angle	(300A,0199)	3	<Shot run gamma angle>
>Setup Technique	(300A,01B0)	3	ISOCENTRIC

RT FRACTION SCHEME MODULE ATTRIBUTES (Table C.8-49 in DICOM standard)			
Attribute Name	Tag	Type	Value
Fraction Group Sequence	(300A,0070)	1	<One item per target>
>Fraction Group Number	(300A,0071)	1	<Sequence number starting at 1>
>Referenced Dose Reference Sequence	(300C,0050)	3	<One item for each dose reference/target with the primary target first in the sequence>
>>Referenced Dose Reference Number	(300C,0051)	1	<Reference to dose reference number>
>>Target Prescription Dose	(300A,0026)	3	<Target prescription dose [Gy]>
>Number of	(300A,0078)	2	<Number of fractions>

Fractions Planned			
>Number of Beams	(300A,0080)	1	<Number of shots>
>Number of Brachy Application Setups	(300A,00A0)	1	0
>Referenced Beam Sequence	(300C,0004)	1C	<One item per shot>
>>Beam Dose Specification Point	(300A,0082)	3	<Dose reference point of the target in DICOM patient coordinates >
>>Beam Dose	(300A,0084)	3	<Dose [Gy] delivered by the shot in the Beam Dose Specification Point>
>>Beam Meterset	(300A,0086)	3	<Shot time>
>>Referenced Beam Number	(300C,0006)	1	<Reference to beam number>

RT BEAMS MODULE ATTRIBUTES (Table C.8-50 in DICOM standard)			
Attribute Name	Tag	Type	Value
Beam Sequence	(300A,00B0)	1	<One item per shot>
>Beam Number	(300A,00C0)	1	<Sequence number starting at 1>
>Beam Name	(300A,00C2)	3	<User defined treatment prefix><Shot name/ID>
>Beam Type	(300A,00C4)	1	STATIC
>Radiation Type	(300A,00C6)	2	PHOTON
>Treatment Machine Name	(300A,00B2)	2	<User defined radiation unit name>
>Institutional Department Name	(0008,1040)	3	<User defined clinic name>
>Primary Dosimeter Unit	(300A,00B3)	3	MINUTE
>Beam Limiting Device Sequence	(300A,00B6)	1	<Two items. One in the X- and one in the Y-direction>
>>RT Beam Limiting Device Type	(300A,00B8)	1	X and Y
>>Number of Leaf/Jaw Pairs	(300A,00BC)	1	0
>Referenced Patient Setup Number	(300C,006A)	3	<Reference to Patient Setup item>

>Treatment Delivery Type	(300A,00CE)	3	TREATMENT
>Number of Wedges	(300A,00D0)	1	0
>Number of Compensators	(300A,00E0)	1	0
>Number of Boli	(300A,00ED)	1	0
>Number of Blocks	(300A,00F0)	1	0
>Final Cumulative Meterset Weight	(300A,010E)	1C	<Same as meterset for last (2nd) control point.>
>Number of Control Points	(300A,0110)	1	2
>Control Point Sequence	(300A,0111)	1	<2 items>
>>Control Point Index	(300A,0112)	1	0/1
>>Cumulative Meterset Weight	(300A,0134)	2	0/<Shot time>
>>Referenced Dose Reference Sequence	(300C,0050)	3	<One item for each dose reference/target with the primary target first in the sequence>
>>>Referenced Dose Reference Number	(300C,0051)	1	<Reference to dose reference number>
>>>Cumulative Dose Reference Coefficient	(300A,010C)	2	For control point 0: 0 For control point 1 if the dose reference represents the target to which the shot belongs: 1 For control point 1 if the dose reference represents another target: beam dose to the dose reference point of the referenced target divided by the beam dose to the reference point of the target to which the shot belongs.0/1
>>Nominal Beam Energy	(300A,0114)	3	<1.25> Only set for the first control point.
>>Dose Rate Set	(300A,0115)	3	<Shot dose rate [Gy/minutes] corresponding to the calculated meterset>
>>Beam Limiting Device Position Sequence	(300A,011A)	1C	<Two items. One in the X- and one in the Y-direction>
>>>RT Beam Limiting Device Type	(300A,00B8)	1	X and Y
>>>Leaf/Jaw Positions	(300A,011C)	1	Hard coded to -10 and 10 for the X- and Y-direction.

>>Gantry Angle	(300A,011E)	1C	0
>>Gantry Rotation Direction	(300A,011F)	1C	NONE
>>Beam Limiting Device Angle	(300A,0120)	1C	0
>>Beam Limiting Device Rotation Direction	(300A,0121)	1C	NONE
>>Patient Support Angle	(300A,0122)	1C	0
>>Patient Support Rotation Direction	(300A,0123)	1C	NONE
>>Table Top Eccentric Angle	(300A,0125)	1C	0
>>Table Top Eccentric Rotation Direction	(300A,0126)	1C	NONE
>>Table Top Pitch Angle	(300A,0140)	1C	0
>>Table Top Pitch Rotation Direction	(300A,0142)	1c	NONE
>>Table Top Roll Angle	(300A,0144)	1C	0
>>Table Top Roll Rotation Direction	(300A,0146)	1C	NONE
>>Table Top Vertical Position	(300A,0128)	2C	0
>>Table Top Longitudinal Position	(300A,0129)	2C	0
>>Table Top Lateral Position	(300A,012A)	2C	0
>>Isocenter Position	(300A,012C)	2C	<Shot position in DICOM patient coordinates >

PATIENT MODULE ATTRIBUTES (Table C.7-1 in DICOM standard)			
Attribute Name	Tag	Type	Value
Patient's Name	(0010,0010)	2	<copied from the images>
Patient ID	(0010,0020)	2	<copied from the images>

Patient's Birth Date	(0010,0030)	2	<copied from the images>
Patient's Sex	(0010,0040)	2	<copied from the images>

GENERAL STUDY MODULE ATTRIBUTES (Table C.7-3 in DICOM standard)			
Attribute Name	Tag	Type	Value
Study Instance UID	(0020,000D)	1	<copied from the images>
Study Date	(0008,0020)	2	<copied from the images>
Study Time	(0008,0030)	2	<copied from the images>
Referring Physician's Name	(0008,0090)	2	<copied from the images>
Study ID	(0020,0010)	2	<copied from the images>
Accession Number	(0008,0050)	2	<copied from the images>
Study Description	(0008,1030)	3	<copied from the images>

PATIENT STUDY MODULE ATTRIBUTES (Table C.7-4a in DICOM standard)			
Attribute Name	Tag	Type	Value
Admitting Diagnoses Description	(0008,1080)	3	<Diagnosis string for the examination>
Admitting Diagnoses Code Sequence	(0008,1084)	3	<One item per diagnosis>
>Code Value	(0008,0100)	1	See 13.2
>Coding Scheme Designator	(0008,0102)	1	ELEKTA GAMMAPLAN
>Coding Scheme Version	(0008,0103)	1C	1.1
>Code Meaning	(0008,0104)	1	See 13.2

RT SERIES MODULE ATTRIBUTES (Table C.8-37 in DICOM standard)			
Attribute Name	Tag	Type	Value
Modality	(0008,0060)	1	RTDOSE/RTSTRUCT/RTPLAN
Operators Name	(0008,1070)	2	RTPLAN: <Operator that approved the plan> Else: Empty

Series Instance UID	(0020,000E)	1	<generated UID>
Series Number	(0020,0011)	2	Empty

FRAME OF REFERENCE MODULE ATTRIBUTES (Table C.7-6 in DICOM standard)			
Attribute Name	Tag	Type	Value
Frame of Reference UID	(0020,0052)	1	<copied from the images>
Position Reference Indicator	(0020,1040)	2	<copied from the images>

GENERAL EQUIPMENT MODULE ATTRIBUTES (Table C.7-8 in DICOM standard)			
Attribute Name	Tag	Type	Value
Manufacturer	(0008,0070)	2	Elekta
Manufacturer's Model Name	(0008,1090)	3	GammaPlan
Software Versions	(0018,1020)	3	<GammaPlan version number>

APPROVAL MODULE ATTRIBUTES (Table C.8-52 in DICOM standard)			
Attribute Name	Tag	Type	Value
Approval Status	(300E,0002)	1	UNAPPROVED/APPROVED/REJECTED
Review Date	(300E,0004)	2C	If approval status is UNAPPROVED or if plan approved in a version prior to LGP 11.0: Empty Else: <treatment plan approval date>
Review Time	(300E,0005)	2C	If approval status is UNAPPROVED or if plan approved in a version prior to LGP 11.0: Empty Else: <treatment plan approval time>
Reviewer Name	(300E,0008)	2C	If approval status is UNAPPROVED: Empty Else: <username>

SOP COMMON MODULE ATTRIBUTES (Table C.12-1 in DICOM standard)			
--	--	--	--

Attribute Name	Tag	Type	Value
SOP Class UID	(0008,0016)	1	<SOP Class UID>
SOP Instance UID	(0008,0018)	1	<generated UID>
Specific Character Set	(0008,0005)	1C	<copied from the images>
Instance Creation Date	(0008,0012)	3	<date of creation>
Instance Creation Time	(0008,0013)	3	<time of creation>

Table 18: DICOM RT Attributes exported by Leksell GammaPlan®.

11 Appendix E: Processing of CBCT images generated by Leksell Gamma Knife®

The transformation between the Leksell coordinate system and the DICOM patient coordinate system that the images are expressed in is a mirroring of the y- and z-axis and can be expressed as:

$$T_{Leksell \rightarrow DICOM \text{ patient}} = \begin{bmatrix} 1 & 0 & 0 & 0 \\ 0 & -1 & 0 & 0 \\ 0 & 0 & -1 & 0 \\ 0 & 0 & 0 & 1 \end{bmatrix}$$

The following attributes are set in CBCT images generated by Leksell Gamma Knife®.

CT IMAGE MODULE ATTRIBUTES (Table C.8-3 in DICOM standard)		
Attribute Name	Tag	Value/Comment
Image Type	(0008,0008)	ORIGINAL\PRIMARY\AXIAL
KVP	(0018,0060)	According to the selected CBCT pre-set
CTDIvol	(0018,9345)	According to the selected CBCT pre-set
Acquisition Number	(0020,0012)	Empty
Samples Per Pixel	(0028,0002)	1
Photometric Interpretation	(0028,0004)	MONOCHROME2
Bits Allocated	(0028,0100)	16
Bits Stored	(0028,0101)	16
High Bit	(0028,0102)	15
Rescale Intercept	(0028,1052)	-1024
Rescale Slope	(0028,1053)	1

FRAME OF REFERENCE MODULE ATTRIBUTES (Table C.7-6 in DICOM standard)		
Attribute Name	Tag	Value/Comment
Frame Of Reference Uid	(0020,0052)	The SOP Instance UID of the first slice of the scan
Position Reference Indicator	(0020,1040)	Empty

GENERAL EQUIPMENT MODULE ATTRIBUTES (Table C.7-8 in DICOM standard)		
Attribute Name	Tag	Value/Comment

Manufacturer	(0008,0070)	Elekta
Manufacturers Model Name	(0008,1090)	"LGK Icon" or "Elekta Esprit" depending on LGK model.
Software Versions	(0018,1020)	CS-Software\<version>\ DICOM-Interface\<version>

GENERAL IMAGE MODULE ATTRIBUTES (Table C.7-9 in DICOM standard)

Attribute Name	Tag	Value/Comment
Instance Number	(0020,0013)	The instance number will be 1 for the first image in a series.
Acquisition Date	(0008,0022)	Date the CBCT scan started
Acquisition Time	(0008,0032)	Time the CBCT scan started

GENERAL SERIES MODULE ATTRIBUTES (Table C.7-5a in DICOM standard)

Attribute Name	Tag	Value/Comment
Modality	(0008,0060)	CT
Series Instance Uid	(0020,000E)	UID generated by Leksell Gamma Knife®
Series Number	(0020,0011)	1
Series Date	(0008,0021)	Date of creation of the series
Series Time	(0008,0031)	Time of creation of the series
Body Part Examined	(0018,0015)	HEADNECK
Patient Position	(0018,5100)	HFS

GENERAL STUDY MODULE ATTRIBUTES (Table C.7-3 in DICOM standard)

Attribute Name	Tag	Value/Comment
Study Instance UID	(0020,000D)	UID generated by Leksell Gamma Knife®
Study Date	(0008,0020)	Date of creation of the study
Study Time	(0008,0030)	Time of creation of the study
Referring Physicians Name	(0008,0090)	Empty
Study Id	(0020,0010)	Empty

Accession Number	(0008,0050)	Empty
------------------	-------------	-------

IMAGE PIXEL MODULE ATTRIBUTES (Table C.7-11a in DICOM standard)		
Attribute Name	Tag	Value/Comment
Pixel Representation	(0028,0103)	1
Pixel Data	(7FE0,0010)	The pixel data of the image

IMAGE PLANE MODULE ATTRIBUTES (Table C.7-10 in DICOM standard)		
Attribute Name	Tag	Value/Comment
Pixel Spacing	(0028,0030)	The pixel spacing of the image
Image Orientation Patient	(0020,0037)	See explanation about coordinates above.
Image Position Patient	(0020,0032)	See explanation about coordinates above.
Slice Thickness	(0018,0050)	The slice thickness of the image

PATIENT MODULE ATTRIBUTES (Table C.7-1 in DICOM standard)		
Attribute Name	Tag	Value/Comment
Patient's Name	(0010,0010)	Last name^First name Value entered in Leksell GammaPlan®
Patient Id	(0010,0020)	Value entered in Leksell GammaPlan®
Patients Birth Date	(0010,0030)	Value entered in Leksell GammaPlan®
Patients Sex	(0010,0040)	Value entered in Leksell GammaPlan®

SOP COMMON MODULE ATTRIBUTES (Table C.12-1 in DICOM standard)		
Attribute Name	Tag	Value/Comment
Sop Class Uid	(0008,0016)	1.2.840.10008.5.1.4.1.1.2
Sop Instance Uid	(0008,0018)	UID generated by Leksell Gamma Knife®
Specific Character Set	(0008,0005)	ISO_IR 192 (UTF-8 encoding)

Table 19: DICOM attributes set in CBCT images generated by Leksell Gamma Knife®.

12 Appendix F: Anonymization of DICOM Attributes

The following DICOM attributes will be anonymized (if present) in data exported as anonymous from Leksell GammaPlan®.

GENERAL STUDY MODULE ATTRIBUTES (Table C.7-3 in DICOM standard)		
Attribute Name	Tag	Anonymized value
Study Instance UID	(0020,000d)	New random unique UID
Referring Physician's Name	(0008,0090)	anonymized
Referring Physician Identification Sequence	(0008,0096)	Empty Value
Physician(s) of Record	(0008,1048)	anonymized
Physician(s) of Record Identification Sequence	(0008,1049)	Empty Value
Name of Physician(s) Reading Study	(0008,1060)	anonymized
Physician(s) Reading Study Identification Sequence	(0008,1062)	Empty Value

GENERAL SERIES MODULE ATTRIBUTES (Table C.7-5a in DICOM standard)		
Attribute Name	Tag	Anonymized value
Performing Physicians Name	(0008,1050)	anonymized
Performing Physician Identification Sequence	(0008,1052)	Empty Value
Operator Identification Sequence	(0008,1072)	Empty Value
Operators' Name	(0008,1070)	anonymized
Series Instance UID	(0020,000e)	New random unique UID

PATIENT MODULE ATTRIBUTES (Table C.7-1 in DICOM standard)		
Attribute Name	Tag	Anonymized value
Patient's Name	(0010,0010)	anonymized^anonymized

Patient ID	(0010,0020)	Randomized number
Patient's Birth Date	(0010,0030)	19000101
Patient's Birth Date in Alternative Calendar	(0010,0033)	19000101
Patient's Death Date in Alternative Calendar	(0010,0034)	19000101
Patient's Alternative Calendar	(0010,0035)	JULIAN
Patient's Sex	(0010,0040)	F
Patient's Birth Time	(0010,0032)	00
Other Patient IDs	(0010,1000)	anonymized
Other Patient Names	(0010,1001)	anonymized
Ethnic Group	(0010,2160)	anonymized
Patient Comments	(0010,4000)	anonymized
Responsible Person	(0010,2297)	anonymized
Responsible Person Role	(0010,2298)	OWNER
Responsible Organization	(0010,2299)	anonymized

PATIENT STUDY MODULE ATTRIBUTES (Table C.7-4a in DICOM standard)		
Attribute Name	Tag	Anonymized value
Patient's Age	(0010,1010)	000Y
Patient's Size	(0010,1020)	0
Patient's Size Code Sequence	(0010,1021)	Empty Value
Patient's Body Mass Index	(0010,1022)	0
Measured AP Dimension	(0010,1023)	0
Measured Lateral Dimension	(0010,1024)	0
Patient's Weight	(0010,1030)	0
Medical Alerts	(0010,2000)	anonymized
Allergies	(0010,2110)	anonymized

Smoking Status	(0010,21A0)	UNKNOWN
Pregnancy Status	(0010,21C0)	4
Last Menstrual Date	(0010,21D0)	19000101
Patient State	(0038,0500)	anonymized
Occupation	(0010,2180)	anonymized
Additional Patient's History	(0010,21B0)	anonymized
Admission ID	(0038,0010)	Randomized number
Patient's Sex Neutered	(0010,2203)	Empty

SOP COMMON MODULE ATTRIBUTES (Table C.12-1 in DICOM standard)		
Attribute Name	Tag	Anonymized value
SOP Instance UID	(0008,0018)	New random unique UID
Institution Name	(0008,0080)	anonymized
Institution Address	(0008,0081)	anonymized
Station Name	(0008,1010)	anonymized
Institutional Department Name	(0008,1040)	anonymized

PATIENT DEMOGRAPHIC MODULE ATTRIBUTES (Table C.2.3 in DICOM standard)		
Attribute Name	Tag	Anonymized value
Patient's Age	(0010,1010)	000Y
Occupation	(0010,2180)	anonymized
Confidentiality Constraint on Patient Data Description	(0040,3001)	anonymized
Patient's Birth Date	(0010,0030)	19000101
Patient's Birth Time	(0010,0032)	00
Patient's Sex	(0010,0040)	F
Patient's Insurance Plan Code Sequence	(0010,0050)	Empty Value

Patient's Primary Language Code Sequence	(0010,0101)	Empty Value
Patient's Primary Language Modifier Code Sequence	(0010,0102)	Empty Value
Patient's Size	(0010,1020)	0
Patient's Weight	(0010,1030)	0
Patient's Size Code Sequence	(0010,1021)	Empty Value
Patient's Address	(0010,1040)	anonymized
Military Rank	(0010,1080)	anonymized
Branch of Service	(0010,1081)	anonymized
Country of Residence	(0010,2150)	anonymized
Region of Residence	(0010,2152)	anonymized
Patient's Telephone Numbers	(0010,2154)	anonymized
Patient's Telecom Information	(0010,2155)	anonymized
Ethnic Group	(0010,2160)	anonymized
Patient's Religious Preference	(0010,21F0)	anonymized
Patient Comments	(0010,4000)	anonymized
Responsible Person	(0010,2297)	anonymized
Responsible Person Role	(0010,2298)	OWNER
Responsible Organization	(0010,2299)	anonymized

VISIT ADMISSION MODULE ATTRIBUTES (Table C.3-4 in DICOM standard)		
Attribute Name	Tag	Anonymized value
Referring Physician's Address	(0008,0092)	anonymized
Referring Physician's Telephone Numbers	(0008,0094)	anonymized

IMAGING SERVICE REQUEST MODULE ATTRIBUTES (Table C.4-12 in DICOM standard)

Attribute Name	Tag	Anonymized value
Requesting Physician	(0032,1032)	anonymized
Requesting Physician Identification Sequence	(0032,1031)	Empty Value
Referring Physician's Name	(0008,0090)	anonymized
Referring Physician Identification Sequence	(0008,0096)	Empty Value

PATIENT IDENTIFICATION MODULE ATTRIBUTES (Table C.2-2 in DICOM standard)		
Attribute Name	Tag	Anonymized value
Patient's Birth Name	(0010,1005)	anonymized
Other Patient IDs Sequence	(0010,1002)	Empty Value
Patient's Mother's Birth Name	(0010,1060)	anonymized

Table 20: Significant Elements when Anonymizing DICOM Objects

13 Appendix G: Standard Extended/ Specialized / Private SOP Classes

13.1 Private Data Elements

Private Attributes are added to the RT Plan exported by Leksell GammaPlan® if the Dose Reference Type (300A,0020) is TARGET. The used group is 0009 and the private identification code is added to element 0010. Thereby we have reserved the block 0009,1000 – 0009,10FF. The private attributes are added to the Dose Reference Sequence (300A,0010), which contains one item for each target.

Attribute Name	Tag	Type	Value Type	Value Multiplicity	Attribute Description	Value
> Implementor Identification Code	(0009,0010)	1	LO	1	Identifier for the implementor reserving the private elements.	ELEKTA GAMMAPLAN
> Target Bounding Box Size	(0009,1020)	3	DS	3	A vector defining the size in the X, Y and Z directions of the Patient Coordinate System, the values given in mm of a bounding box containing the target.	
> Target Volume Size	(0009,1021)	3	DS	1	The size in cubic centimeters of the target volume (TV). Only included if there exists a corresponding user defined target volume.	
> Prescription Isodose Volume Size	(0009,1022)	3	DS	1	The size in cubic centimeters of the the prescription isodose volume (PIV).	
> Prescription Isodose Volume in Target	(0009,1023)	3	DS	1	The size in cubic centimeters of the part of the prescription isodose volume (PIV) that is inside the target volume (TV), i.e. $\text{Volume}(\text{PIV} \cap \text{TV})$. Error! Bookmark not defined.	
> Paddick Conformity Index	(0009,1024)	3	DS	1	The conformity index defined by Paddick: $\text{Volume}(\text{PIV} \cap \text{TV})^2 / (\text{Volume}(\text{TV}) * \text{Volume}(\text{PIV}))^3$	
> Dose Gradient Index	(0009,1025)	3	DS	1	The quotient between the half-prescription isodose volume size and the prescription isodose volume size. Only included if could be calculated, i.e. only if the dose drops below the half-prescription isodose within the target matrix.	
> 12 Gy Volume	(0009,1026)	3	DS	1	The size in cubic centimeters of the the volume receiving more than 12 Gy.	

> Target Prescription Isodose	(0009,1027)	3	DS	1	The isodose in percent to which the dose (300A,0026) is prescribed.	
-------------------------------	-------------	---	----	---	---	--

Table 21: Private Data Elements included in the RT Plan exported by Leksell GammaPlan®.

13.2 Diagnosis Code Values

The Code Meaning attribute (0008,0104) and Code Value attribute (0008,0100) in Patient Study Module can have the following values when exported as part of the RT Dose IOD, RT Structure Set IOD and RT Plan IOD.

Code Meaning	Code Value
OCD	R1001
Depression	R1002
Other behavioral disorder	R1099
Chordoma	R1101
Chondrosarcoma	R1201
Craniopharyngioma	R1301
Mesial temporal lobe epilepsy	R1401
Hypothalamic hamartoma	R1402
Other epilepsy	R1499
Juvenile pilocytic astrocytoma	R1501
Diffuse astrocytoma, grade 2	R1502
Anaplastic astrocytoma, grade 3	R1503
Glioblastoma	R1504
Oligodendroglioma, grade 2 or 3	R1505
Ganglioglioma	R1506
Medulloblastoma	R1507
Ependymoma, grade 2 or 3	R1508
Other glial neoplasm	R1599
Hemangioblastoma	R1601
Meningioma, all grades	R1701
Metastasis - single	R1801
Metastases - multiple	R1802
Parkinson's disease	R1901
Essential tremor	R1902
Other movement disorder	R1999
Uveal melanoma	R2001
Glaucoma	R2002
Macular degeneration	R2003
Other ocular	R2099
Pain	R2101
Cluster headache	R2102

Pineocytoma	R2201
Pineoblastoma	R2202
Germinoma	R2203
Non germinomatous germ cell tumor	R2204
Other pineal region	R2299
Pituitary adenoma	R2301
Vestibular schwannoma	R2401
Trigeminal schwannoma	R2402
Jugular foramen schwannoma	R2403
Other schwannoma	R2499
Trigeminal neuralgia	R2501
Arteriovenous malformation	R2601
Cavernous malformation	R2602
Dural arteriovenous fistula	R2603
Other vascular	R2699
Hemangioma	R9001
Hemangiopericytoma, grade 2 or 3	R9002
Neurocytoma	R9003
Choroid plexus papilloma	R9004
Other benign tumor	R9099
Nasopharyngeal carcinoma	R9101
Adenoid cystic carcinoma	R9102
Squamous cell carcinoma	R9103
Other malignant tumor	R9199
Physics Test ³	R9801
<Prior Classification> ⁴	R9999

Table 22: Possible values for Code Meaning attribute (0008,0104) and Code Value attribute (0008,0100) when exported by Leksell GammaPlan®

³ R98 is a Non-clinical Diagnosis group.

⁴ The diagnosis used prior to TPS 10.2 (was not mapped to any specific code)